

# INSTALLATION INSTRUCTION FIRE / SMOKE DAMPER

## FLANGED SYSTEM BREAKAWAY CONNECTIONS INSTALLATION INSTRUCTIONS SUPPLEMENT

### APPLICATION

Flange breakaway connection for fire damper or combination fire smoke damper. These instructions apply to a connection between a manufactured flange system by Ward, Ductmate, Nexus, TDC and TDF. These connections allow the use of combining mixed flange types or like for like. The following instruction depicts the use of Metal or Plastic Cleats, Butyl or Neoprene Gasket, and Bolted or Non-Bolted corners. Also the flanges may be connected with the use of #10 screws without the cleats.

1. Install the manufactured flange system onto the damper sleeve or duct per the manufacturer's instructions.
2. Seal the two flange systems together Neoprene or Butyl gasket may be applied to the mating surfaces.
3. Align the two flange systems together. A 3/8 in. (9mm) bolt may be used in the corners to help with the alignment. The bolt does not have to be removed. Bolted corners are permitted.
4. Install the cleat or #10 tek screw, approximately equally spaced, per the schedule described:

- Width or height less than 24 in. (610mm); use one cleat or screw per side
- Width or height 24 in. (610 mm) to less than 36 in. (914mm); use 2 cleats or screws per side
- Width or height 36 in. (914mm) to less than 54 in. (1372mm); use 3 cleats or screws per side
- Width or height 54 in. (1372mm) to less than 72 in. (1829mm); use 4 cleats or screws per side
- Width or height 72 in. (1829mm) or greater; use 5 cleats or screws per side.

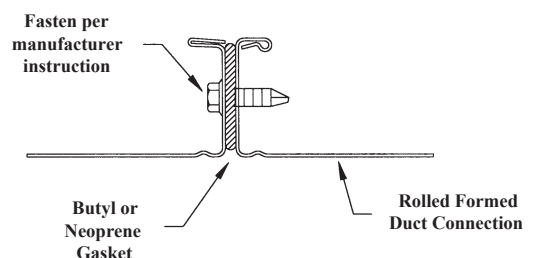
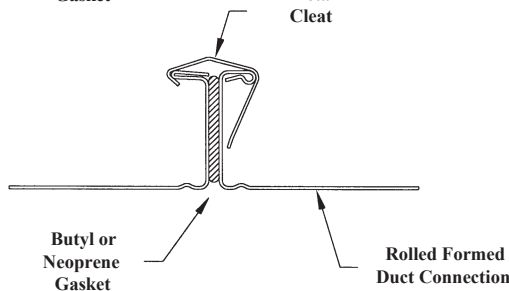
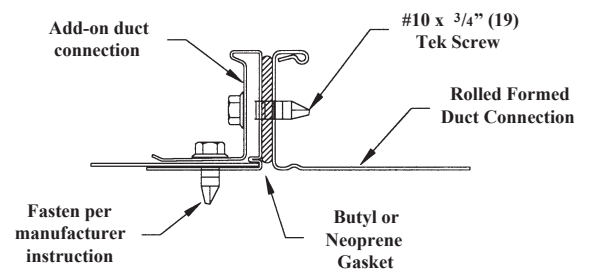
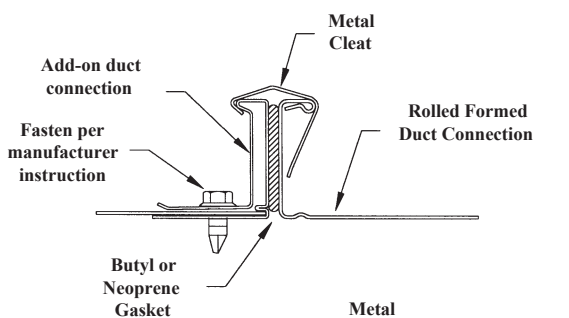
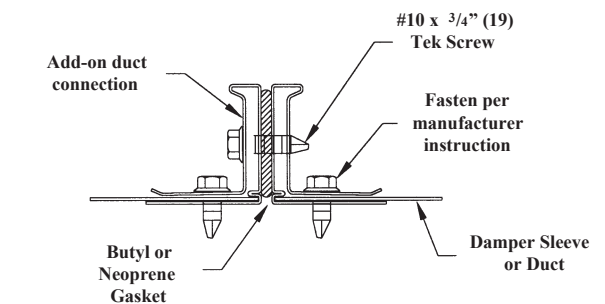
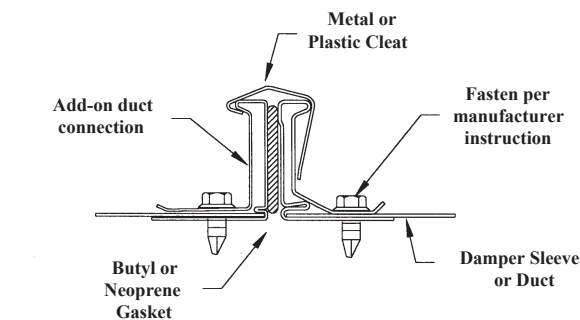
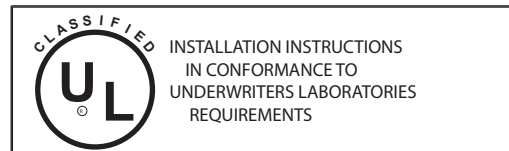

ALL STATED SPECIFICATIONS ARE SUBJECT TO CHANGE WITHOUT NOTICE OR OBLIGATION.